

Laplace Transform & Z-Transform

Dept. of Electrical and Electronic Engineering

December 20, 2019



Why Laplace Transform?



Name after
Pierre-Simon Laplace (1749–1827)

- Laplace transform is a generalization of continuous-time Fourier transform
- It provides additional tools and insights on signals and systems
 - ▶ E.g., poles and zeros
- It can be applied to the scenarios where Fourier transform does not exist
 - ▶ E.g., instable system

Laplace Transform

- e^{st} is the eigenfunction of LTI system:

$$e^{st} \longrightarrow H(s)e^{st} \text{ where } H(s) = \int_{-\infty}^{+\infty} h(t)e^{-st} dt$$

- In Fourier transform, we let $s = j\omega$ (pure imaginary)
- In Laplace transform, s is general complex number $s = \sigma + j\omega$

$$\text{Laplace Transform: } X(s) = \int_{-\infty}^{+\infty} x(t)e^{-st} dt$$

- **Question:** How to calculate Laplace transform from knowledge of Fourier transform.



Laplace Transform: Example

- $x(t) = e^{-at}u(t)$:

$$\begin{aligned}X(s) = X(\sigma + j\omega) &= \int_0^{+\infty} e^{-at} e^{(-\sigma - j\omega)t} dt = \int_0^{+\infty} e^{-(a+\sigma)t} e^{-j\omega t} dt \\ &= \frac{1}{s+a} \quad \text{Re}\{s\} > -a \quad (\text{or } \sigma > -a) \quad a < 0?\end{aligned}$$

- $x(t) = -e^{-at}u(-t)$:

$$\begin{aligned}X(s) = X(\sigma + j\omega) &= -\int_{-\infty}^0 e^{-at} e^{(-\sigma - j\omega)t} dt \\ &= \frac{1}{s+a} \quad \text{Re}\{s\} < -a \quad (\text{or } \sigma < -a) \quad a > 0?\end{aligned}$$

- Laplace transform should be specified by both algebraic expression and region of convergence (ROC)

Pole-Zero Plot

- $3e^{-2t}u(t) - 2e^{-t}u(t) \longleftrightarrow \frac{s-1}{s^2+3s+2} \quad \text{Re}\{s\} > -1$

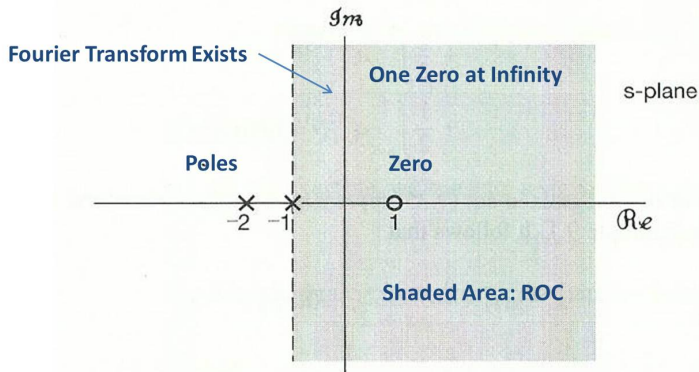

- To within a scale factor, a rational Laplace transform can be specified by the pole-zero plot and its ROC

Region of Convergence

Property (1)

The ROC of $X(s)$ consist of strips parallel to the $j\omega$ -axis in the s -plane

- $X(s) = \mathcal{F}\{x(t)e^{-\sigma t}\}$

Property (2)

For rational Laplace transform, the ROC does not contain any poles

- Poles: $X(s) \rightarrow \infty$

- $\frac{1-e^s}{s}$



Property (3)

If $x(t)$ is of finite duration and is absolutely integrable, then the ROC is the entire s -plane

Property (4,5)

If $x(t)$ is left sided (*right sided*), and if the line $\text{Re}\{s\} = \sigma_0$ is in the ROC, then all values of s for which $\text{Re}\{s\} < \sigma_0$ ($\text{Re}\{s\} > \sigma_0$) will also be in the ROC

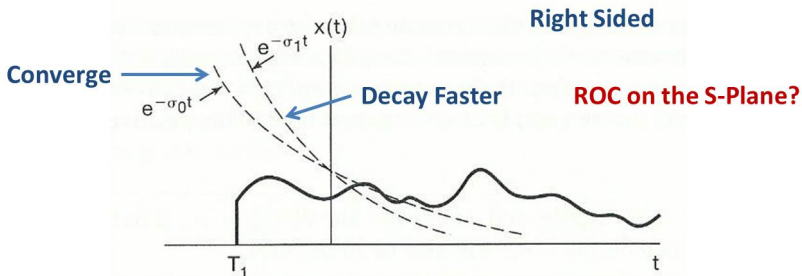

Property (6)

If $x(t)$ is two sided, and if the line $\text{Re}\{s\} = \sigma_0$ is in the ROC, then the ROC will consist of a strip in the s -plane that include the line $\text{Re}\{s\} = \sigma_0$

- How to derive it from Property 4 and 5?
- ROC: null, left-half plane, right-half plane, single strip, s -plane

Property (7)

If $X(s)$ is rational, then its ROC is bounded by poles or extends to infinity.

Property (8)

If $X(s)$ is rational, then if $x(t)$ is right sided (*left sided*), the ROC is the region in the s -plane to the right (*left*) of the rightmost (*leftmost*) pole

ROC: Example

- $X(s) = \frac{1}{(s+1)(s+2)} = \frac{1}{s+1} - \frac{1}{s+2}$ has two poles $s = -1, -2$
 - ▶ $X(s) = \frac{1}{s+1}$: $e^{-t}u(t)$ or $-e^{-t}u(-t)$?
 - ▶ $X(s) = \frac{1}{s+2}$: $e^{-2t}u(t)$ or $-e^{-2t}u(-t)$?

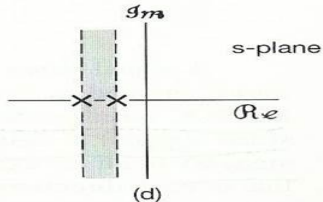
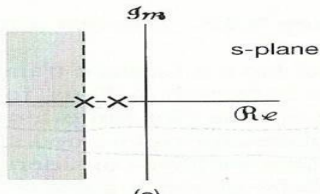
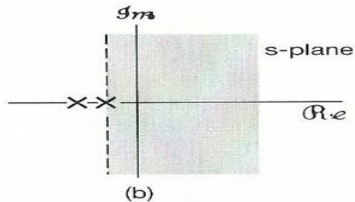
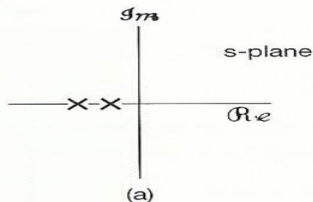

Inverse Laplace Transform

$$X(\sigma + j\omega) = \mathcal{F}\{x(t)e^{-\sigma t}\}$$

\Downarrow

$$x(t) = e^{\sigma t} \mathcal{F}^{-1}\{X(\sigma + j\omega)\}$$

- Inverse Laplace transform:

$$x(t) = \frac{1}{2\pi j} \int_{\sigma-j\infty}^{\sigma+j\infty} X(s)e^{st} ds$$

- Another approach: partial fraction expansion

- ▶ Algebraic expression:

$$X(s) = \sum_{i=1}^m \frac{A_i}{s + a_i}$$

- ▶ ROC: ROC of each term should contain the ROC of $X(s)$



LTI Systems

Time Domain: $y(t) = h(t) * x(t) \longleftrightarrow$ S-Domain: $Y(s) = H(s)X(s)$

- $H(s)$: system function or transfer function
- **Causality**: impulse response is right sided
 - ▶ The ROC of causal system is a right-half plane (**How about the inverse?**)
 - ▶ For rational system function, causality is equivalent to the ROC being the right-half plane to the right of rightmost pole
 - ▶ **Question**: How about anticausal ($h(t) = 0, t > 0$)?
- **Stability**: An LTI system is stable if and only if the ROC of its system function $H(s)$ include the $j\omega$ -axis
 - ▶ Example: $H(s) = \frac{s-1}{(s+1)(s-2)}$
 - ▶ **Unstable systems have Laplace transform**
- **Question**: What's the ROC of causal stable LTI system with rational system function?



LTI System: Differential Equation

$$\begin{aligned}\sum_{k=0}^N a_k \frac{d^k y(t)}{dt^k} &= \sum_{k=0}^M b_k \frac{d^k x(t)}{dt^k} \\ &\Downarrow \\ \left(\sum_{k=0}^N a_k s^k \right) Y(s) &= \left(\sum_{k=0}^M b_k s^k \right) X(s) \\ &\Downarrow \\ H(s) &= \left(\sum_{k=0}^M b_k s^k \right) / \left(\sum_{k=0}^N a_k s^k \right)\end{aligned}$$

- ROC: stable, causal ...
- **Reading Assignment:** Necessary knowledge of Laplace transform in Section 9.0-9.3 9.4.1 9.5-9.7

Z-Transform

- Discrete-time system:

$$z^n \rightarrow H(z)z^n \text{ where } H(z) = \sum_{n=-\infty}^{+\infty} h[n]z^{-n}$$

- In Fourier transform, $z = e^{j\omega}$ (unit magnitude)
- In z-transform, z is general complex number $z = re^{j\omega}$

$$\text{z-transform: } X(z) = \sum_{n=-\infty}^{+\infty} x[n]z^{-n}$$

- **Question:** What's the relation between z-transform and discrete-time Fourier transform?



Z-Transform: Example

- $x[n] = a^n u[n]$:

$$X(z) = \sum_{n=0}^{\infty} (az^{-1})^n = \frac{1}{1 - az^{-1}} = \frac{z}{z - a}, \quad |z| > |a|$$

- $x[n] = -a^n u[-n - 1]$:

$$\begin{aligned} X(z) &= - \sum_{n=-\infty}^{+\infty} a^n u[-n - 1] z^{-n} = 1 - \sum_{n=0}^{\infty} (a^{-1}z)^n = 1 - \frac{1}{1 - a^{-1}z} \\ &= \frac{z}{z - a}, \quad |z| < |a| \end{aligned}$$

- Z-transform should be specified by both algebraic expression and region of convergence (ROC)

Pole-Zero Plot

$$a^n u[n] \quad (|a| < 1)$$

Fourier Transform Exists

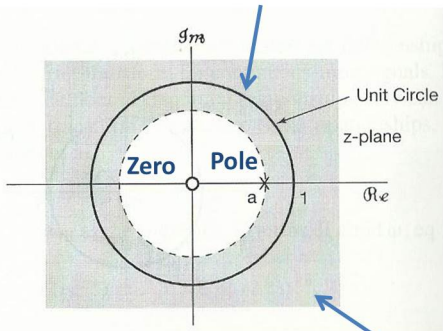

$$-a^n u[-n-1] \quad (|a| < 1)$$

Fourier Transform Diverge

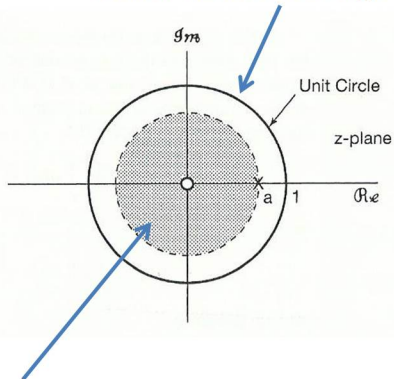

Shaded Area: ROC --- Ring



Region of Convergence (1/3)

Property (1)

The ROC of $X(z)$ consists of a ring in the z -transform centered about the origin

- $X(z) = \mathcal{F}\{x[n]r^{-n}\}$

Property (2)

The ROC does not contain any pole

Property (3)

If $x[n]$ is of finite duration, then the ROC is the entire z -plane, except possible $z = 0$ and/or $z = \infty$

- Question:** When is $z = 0$ or $z = \infty$ in ROC?

ROC: Example

$$x[n] = a^n \quad 0 \leq n \leq N-1, a > 0$$

$$X(z) = \sum_{n=0}^{N-1} a^n z^{-n} = \frac{1}{z^{N-1}} \frac{z^N - a^N}{z - a}$$

Zeros: $z_k = ae^{j2k\pi/N}, k=1, \dots, N-1$

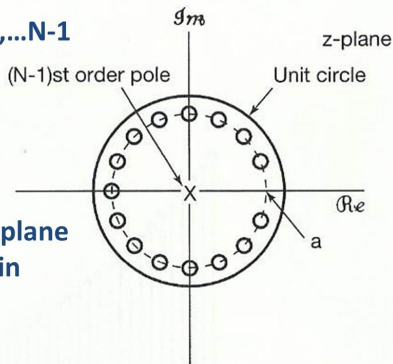

ROC is the entire z-plane
except the origin



Region of Convergence (2/3)

Property (4,5)

If $x[n]$ is a right-sided (*left-sided*) sequence, and if the circle $|z| = r_0$ is in the ROC, then all finite value of z for which $|z| > r_0$ ($0 < |z| < r_0$) will also be in the ROC

Property (6)

If $x[n]$ is a two-sided sequence, and if the circle $|z| = r_0$ is in the ROC, then the ROC will consist of a ring including the circle $|z| = r_0$

Right Sided

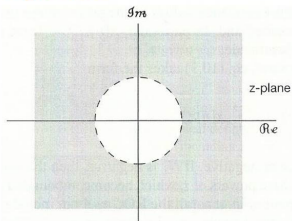

Left Sided

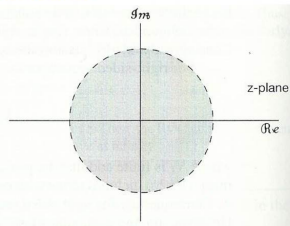

Two Sided

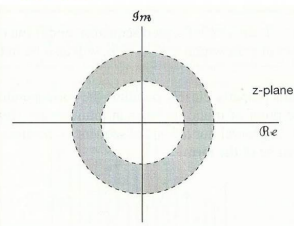

Region of Convergence (3/3)

Property (7)

If $X(z)$ is rational, then its ROC is bounded by poles or extends to infinity

Property (8,9)

If $X(z)$ is rational and $x[n]$ is right sided (*left sided*), then the ROC is the region outside the outmost pole (*inside the innermost nonzero pole, possibly including $z = 0$*)

ROC: Example

$$X(z) = \frac{1}{(1 - \frac{1}{3}z^{-1})(1 - 2z^{-1})} = \frac{z^2}{(z - \frac{1}{3})(z - 2)}$$

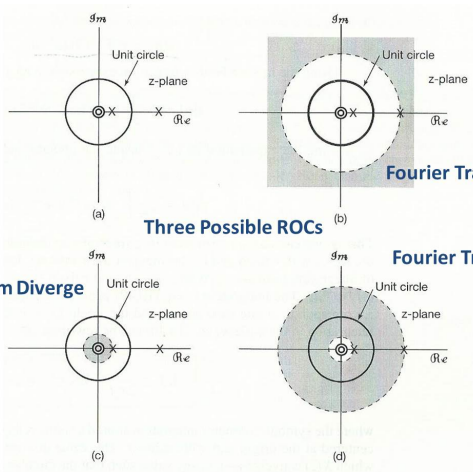

Inverse Z-Transform

- Approach I: via Fourier Transform

$$X(re^{j\omega}) = \mathcal{F}\{x[n]r^{-n}\} \Rightarrow x[n] = r^n \mathcal{F}^{-1}\{X(re^{j\omega})\}$$

- Approach II: via definition

$$x[n] = \frac{1}{2\pi j} \oint X(z)z^{n-1}dz \quad \text{Integration around a counter-clockwise circle}$$

- Approach III: partial fraction expansion

$$X(z) = \sum_{i=1}^m \frac{A_i}{1 - a_i z^{-1}}$$

- Approach IV: power-series expansion

$$\text{E.g., } X(z) = 4z^2 + 2 + 3z^{-1}$$

$$y[n] = h[n] * x[n] \longleftrightarrow Y(z) = H(z)X(z)$$

- $H(z)$ is the system function or transfer function
- **Causality:**
 - ▶ the ROC is the exterior of a circle, including infinity
 - ▶ Rational: (a) the ROC is the exterior of a circle outside the outermost pole; (b) order of numerator cannot be greater than the order of denominator
- **Stability:**
 - ▶ The ROC includes $|z| = 1$
 - ▶ Causal & Rational: all the poles lie inside the unit circle

LTI Systems: Difference Equation

$$\begin{aligned}\sum_{k=0}^N a_k y[n-k] &= \sum_{k=0}^M b_k x[n-k] \\ &\Downarrow \\ \sum_{k=0}^N a_k z^{-k} Y(z) &= \sum_{k=0}^M b_k z^{-k} X(z) \\ &\Downarrow \\ H(z) &= \left(\sum_{k=0}^M b_k z^{-k} \right) / \left(\sum_{k=0}^N a_k z^{-k} \right)\end{aligned}$$

- ROC: causal, stable, ...
- **Reading Assignment:** Necessary knowledge of z-transform in Section 10.0-10.3 10.4.1 10.5-10.7

